

Resin Nut Lead Screw

Shaft diameter dia. 10, 12mm Accuracy grade C7, C10

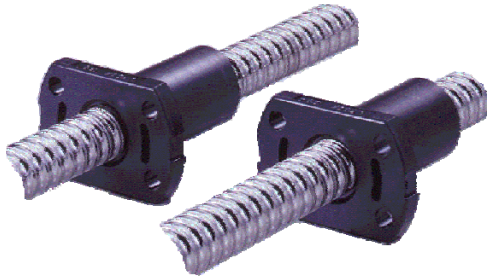

Inexpensive price and compact design to compare to Ball screw.

Accuracy grade

Model Number	Mean travel deviation	Shaft center runnout	Initial axial play		
PY1004GP(SP)-0400A	C10 +/-0.21/300	0.15	0.1 or less		
PY1004GP(SP)-0600A		0.25			
PY1010GP(SP)-0400A		0.15			
PY1010GP(SP)-0600A		0.25			
PY1204GP(SP)-0400A		0.15			
PY1204GP(SP)-0800A		0.32			
PY1210GP(SP)-0400A		0.15			
PY1210GP(SP)-0800A		0.32			
PW1004GP(SP)-0400A		C7 +/-0.05/300		0.10	0.05 or less
PW1004GP(SP)-0600A				0.15	
PW1010GP(SP)-0400A	0.10				
PW1010GP(SP)-0600A	0.15				
PW1204GP(SP)-0400A	0.10				
PW1204GP(SP)-0800A	0.20				
PW1210GP(SP)-0400A	0.10				
PW1210GP(SP)-0800A	0.20				

ORDERING INSTRUCTION

■ WITHOUT END MACHINING

P ① ② ③ ④ ⑤ - ⑥ A

■ WITH END MACHINING

P ① ② ③ ④ ⑤ - ⑥ X ⑦ ⑧ Y

- ① Series : Y - C10 class, W - C7 class
- ② Shaft dia. (mm) : 10, 12
- ③ Lead (mm) : 04, 10
- ④ Shaft material : G - S45C, S - (SUS304)
- ⑤ Nut material : P (PPS)
- ⑥ Allover length (mm)
- ⑦ Thread length (mm)
- ⑧ Accuracy grade : CA (PY), C7 (PW)

Shaft (Rolled)

- Two selections
GP : S45C (No induction hardening)
SP : SUS304 (No induction hardening)
- Surface roughness
Ra0.05 micron meter

Lubrication

- Recomending grease :
Alvania grease No.2 by Showa Shell Sekiyu K.K.
- The anti-rust oil on the shaft and in the nut can be lubrication so that it can work on as lubrication.
- First maintenance shall be held about a few months
If the grease is dirty, remove the old grease and regrease.
- After the first maintenance, regrease once a year.

Nut (Injection mold)

- High reliable dimension
Material : High rigidity engineering plastic (PPS)

Contents of Nut (PPS)

Subject	Unit	PPS	PET GF30%	Alminum die casting
Specific gravity	---	2.55	2.70	ASTM-D792
Tensile strength	Mpa	165	343	ASTM-D638
Bending strength	MPa	225	---	ASTM-D790
coefficient of linear expansion	X10 ⁻⁵ /K	1.7 - 1.8	2.1	ASTM-D696

Permissible Axial Load and Revolution Speed

Shaft dia. (mm)	Lead (mm)	Permissible axial load (N)	Permissible revolution speed (min ⁻¹)
10	4	70	3000
	10		
12	4	100	3000
	10		

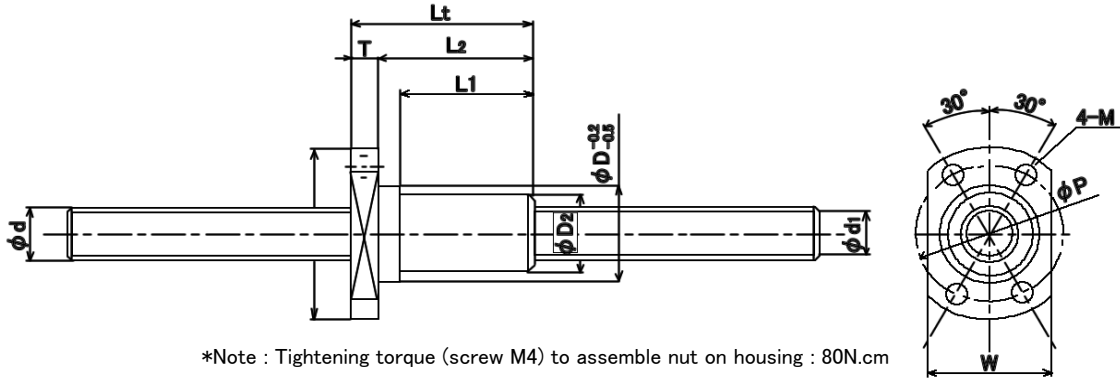

*Note : Tightening torque (screw M4) to assemble nut on housing : 80N.cm

Model Number	shaft dia. (mm)	Lead (mm)	runout	Screw shaft		Nut									Accuracy Grade	Axial play																		
				Overall length	Root dia. d1	Nut barrel			Flange																									
						Outside diameter	Overall length	Nut barrel length		dia.	Thick ness	Mouting		Width																				
D	D2	Lt	L2	L1	D1	T	P.C.D	M	W																									
PY1004GP(SP)R-0400A	10	4	Right	400	(7.8)	19	16	32	27	22	36	5	28	4.5 drill through	22	C10	0.10 or less																	
PY1004GP(SP)R-0600A				600																														
PY1004GP(SP)L-0400A			Left	400																														
PY1004GP(SP)L-0600A				600																														
PY1010GP(SP)R-0400A	10	10	Right	400	(10.0)	22	18	38	33	28	39	5	31		26	C10	0.10 or less																	
PY1010GP(SP)R-0600A				600																														
PY1204GP(SP)R-0400A	12	4	Right	400																														
PY1204GP(SP)R-0800A				800																														
PY1210GP(SP)R-0400A			10	Right										400	(9.6)	22	18	38	33	28	39	5	31	26	C10	0.10 or less								
PY1210GP(SP)R-0800A														800																				
PW1004GP(SP)R-0400A	10	4	Right	400										(7.8)										19	16	32	27	22	36	5	28	22	C7	0.05 or less
PW1004GP(SP)R-0600A				600																														
PW1004GP(SP)L-0400A			Left	400																														
PW1004GP(SP)L-0600A				600																														
PW1010GP(SP)R-0400A	10	10	Right	400	(10.0)	22	18	38	33	28	39	5	31	26	C7	0.05 or less																		
PW1010GP(SP)R-0600A				600																														
PW1204GP(SP)R-0400A	12	4	Right	400																														
PW1204GP(SP)R-0800A				800																														
PW1210GP(SP)R-0400A			10	Right										400	(9.6)	22	18	38	33	28	39	5	31	26	C7	0.05 or less								
PW1210GP(SP)R-0800A														800																				

Axial load and actual torque Guide line of actual torque for motor

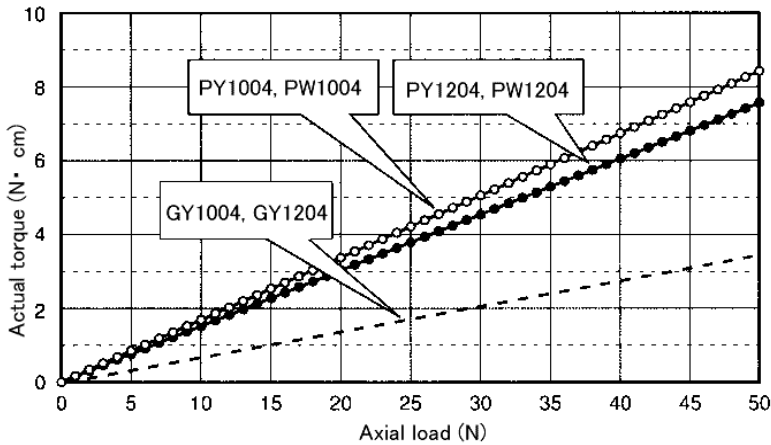

Address : 239, Shimohirama, Saiwai-Ku, Kawasaki, Kanagawa, Japan
 Telephone : +81-44-555-3805
 Fax : +81-44-555-1479
 E-mail : ovs_dtp@kuroda-precision.co.jp
 URL : http://www.kuroda-precision.com

KURODA
 PRECISION INDUSTRIES LTD.